

AS1V H07 SERIES

Current Sensor

Model Number:

AS1V 100 H07
AS1V 200 H07

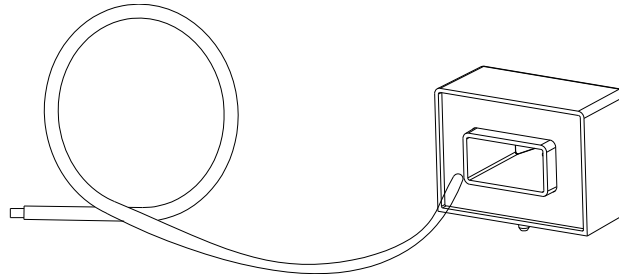

For the electronic measurement of current: DC, AC, pulsed..., with galvanic separation between the primary and the secondary circuits.

Features

- ✧ Open loop current sensor using the Hall Effect.
- ✧ Galvanic separation between primary and secondary.
- ✧ Insulating plastic case recognized according to UL 94-V0.
- ✧ Supply voltage: +5V
- ✧ No insertion loss.
- ✧ Small size
- ✧ Standards:
 - EN50178: 1997
 - IEC 61010-1: 2000
 - UL 508: 2010

Applications

- ✧ AC variable speed
- ✧ Uninterruptible Power Supplies (UPS).
- ✧ Static converters for DC motor drives.
- ✧ Switch Mode Power Supplies (SMPS).
- ✧ Power supplies for welding applications.
- ✧ Battery management.

Safety

This sensor must be used according to IEC61010-1.

This sensor must be used in electric/electronic equipment with respect to applicable standards and safety requirements in accordance with the following manufacturer's operating instructions.

Caution, risk of electrical shock!



When operating the sensor, certain parts of the module can carry hazardous voltage (e.g., Primary busbar, power supply). Ignore this warning can lead to injury and/or cause serious damage.

This sensor is a built-in device, whose conducting parts must be inaccessible after installation. A protective housing or additional shield could be used.

Main supply must be able to be disconnected.

Absolute maximum ratings (not operating)

Parameter	Symbol	Unit	Value
Supply voltage	V_C	V	+ 6 V
Primary conductor temperature	T_B	°C	105
ESD rating, Human Body Model (HBM)	V_{ESD}	kV	4

- ※ Stress above these ratings may cause permanent damage.
- ※ Exposure to absolute maximum ratings for extended periods may degrade reliability.

Environmental and mechanical characteristics

Parameter	Symbol	Unit	Min	Typ	Max	Comment
Ambient operating temperature	T_A	°C	-40		105	
Ambient storage temperature	T_S	°C	-40		125	
Mass	m	g		60		
Standards	EN 50178, IEC 61010-1, UL 508C					

Insulation coordination

Parameter	Symbol	Unit	Value	Comment
Rms voltage for AC insulation test @ 50Hz, 1min	V_d	kV	3.6	
Impulse withstand voltage 1.2/50 μ s	V_w	kV	6.6	
Clearance (pri.- sec.)	d_{c1}	mm	6.3	
Creepage distance (pri.- sec.)	d_{cp}	mm	7.3	
Plastic case	-	-	UL94-V0	
Comparative tracking index	CTI	PLC	3	
Application example	-	-	300V CAT III PD2	Reinforced insulation, according to EN 50178, EN 61010-1.
Application example	-	-	600V CAT III PD2	Basic insulation, according to EN 50178, EN 61010-1.

AS1V H07 SERIES

Electrical data

※ With $T_A = 25^\circ\text{C}$, $V_C = +5\text{V}$, $R_L = 10\text{k}\Omega$, unless otherwise noted.

Parameter	Symbol	Unit	Min	Typ	Max	Comment
Primary nominal rms current	I_{PN}	A	-100 -200		100 200	AS1V 100 H07 AS1V 200 H07
Supply voltage	V_C	V	4.75	5.00	5.25	@ 5%
Current consumption	I_C	mA		12		
Output voltage (Analog) @ I_{PN}	V_{OUT}	V	$V_{OUT} = 2.5 + G_{th} \times I_{PN}$			@ V_C
Offset voltage	V_{OUT}	V	2.485	2.5	2.515	@ $I_P = 0\text{A}$
Load resistance	R_L	k Ω	10			
Electrical offset voltage	V_{OE}	mV	-10		10	
Temperature coefficient of V_{OE}	TCV_{OE}	mV	-10	± 6	10	@ $-40^\circ\text{C} \sim 105^\circ\text{C}$
Hysteresis offset voltage @ $I_P = 0$ after $1 \times I_{PN}$	V_{OM}	mV	-10		10	
Theoretical sensitivity	G_{th}	mV/A		20 10		AS1V 100 H07 AS1V 200 H07
Sensitivity error	ε_G	%	-0.5		0.5	Exclusive of V_{OE}
Temperature of G	TCG	%	-0.5		0.5	@ $-40^\circ\text{C} \sim 105^\circ\text{C}$
Linearity error 0... I_{PN}	ε_L	% of I_{PN}	-0.5		0.5	Exclusive of V_{OE}
Accuracy @ I_{PN}	X	% of I_{PN}	-1		1	Exclusive of V_{OE}
Response time @ 90% of I_{PN}	t_r	μs		3	5	
Frequency bandwidth(-3dB)	BW	kHz	50			

AS1V H07 SERIES

Dimensions (in mm. 1 mm = 0.0394 inch)

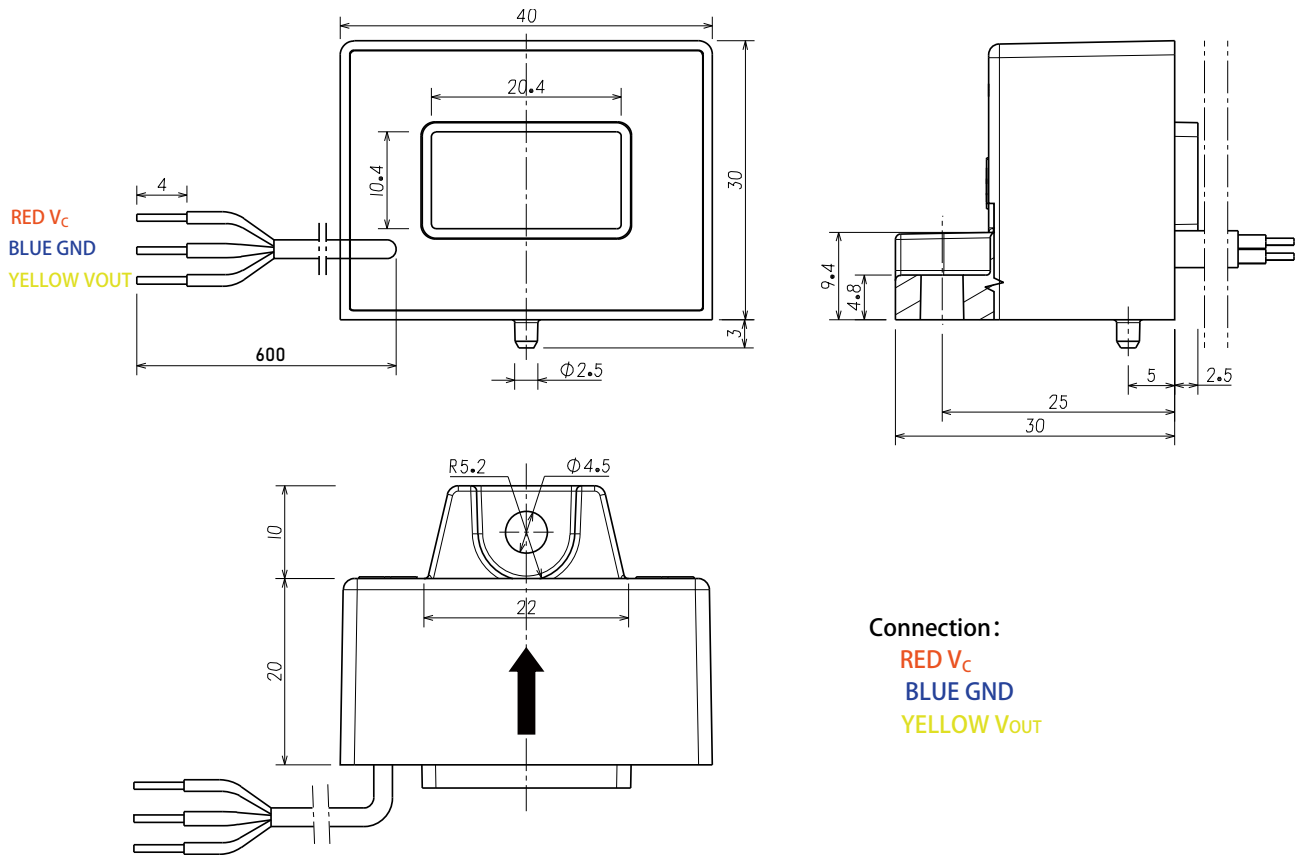

Mechanical characteristics

◇ General tolerance	±0.5 mm
◇ Secondary output	RVVP 3×0.3mm ²
◇ Output line length	600 ±10mm
◇ Primary hole	20.5mm×10.5mm
◇ Sensor	1pc Φ4.5 mm through hole 1pc M4 metal screws

Recommended fastening torque 0.9 N•m (±10%)

Remarks

- ◇ V_{OUT} and I_p are in the same direction, when I_p flows in the direction of arrow.
- ◇ Temperature of the primary conductor should not exceed 105°C.
- ◇ Dynamic performances (di/dt and response time) are best with asingle bar completely filling the primary hole.

This is a standard model. For different applications (measurement, secondary connections...), please contact CHIPSENSE.